

Restricted Earth Fault Protection Maloperation in Power Transformers and Optimal Settings to Improve its Performance

Reza Talebi¹, Mohammad Hassan Moradi^{1,*}

¹ Department of Electrical Engineering, Bu-Ali Sina University, Hamadan, Iran

ARTICLEINFO

ABSTRACT

Article history:

Received 24 April 2023

Received in revised form 18 June 2023

Accepted 29 August 2023

Keywords:

Transformer

Protection

Restricted earth fault

Relay setting

Ct



Copyright: © 2023 by the authors. Submitted for possible open access publication under the terms and conditions of the Creative Commons Attribution (CC BY) license (<https://creativecommons.org/licenses/by/4.0/>)

Power transformers are one of the main components of the power grids. Several main and back up protection relays are provided to protect them against different fault types. Restricted Earth Fault (REF) protection relay is used as main protection to protect transformer against in-zone phase-to-ground faults. This protection has high accuracy to detect earth faults inside the transformer protection zone. Operational experiences show that in some cases and during external high current out-zone faults which leads to current transformers (CTs) core saturation, REF relay operates incorrectly and cause unwanted trip. Relay setting base and operation curve methods to solve the problem have been devised, but the problem has not yet been completely solved. In this article, different fault types such as symmetric/asymmetric, single/multiple phases, low/high current are simulated. Then, causes of REF protection maloperation and commercial relays settings and curves are studied. Optimal setting for the relay is extracted and its effectiveness in different fault types validated by simulating real data with PSCAD and MATLAB software.

1. Introduction

During internal faults inside the power transformer, the amount of damage is proportional to the duration of fault current passing through it. So, the transformer should be disconnected from power as soon as possible. To achieve this, unit protection schemes is used to detect faults and issue quick trip command [1]. Restricted earth fault protection (REF), which is used in power transformers to detect phase-to-earth faults on the winding side with a star connection or a delta winding with a grounding transformer is the main protection for this purpose [2]. REF relay ($I_{d,G}$) is much more sensitive than differential protection ($<I_d$) to detect earth fault on the star winding of transformers. The logic of the REF relay is to compare neutral current (I_Y) at the star point with the vector sum of three phase currents (I_N) [3]. Fig.1

shows connection for the transformer with Yyn(d) vector group.

Increment of load and short circuit current in REF protection scheme would increase CTs ratio error linearly and CTs saturation error nonlinearly. So, Relay settings and algorithm are very important for its operation and prevent incorrect trip in out zone faults. In order to improve its performance, various manufacturers have made changes in its formula of calculating bias and operating currents. Despite of these efforts, there are still many cases of maloperation of REF relay reported in out-zone faults.

* Corresponding author

E-mail address: mhmoradi@basu.ac.ir

 <https://www.orcid.org/0000-0003-1498-0831>

<http://dx.doi.org/10.48308/ijrtei.2023.103637>

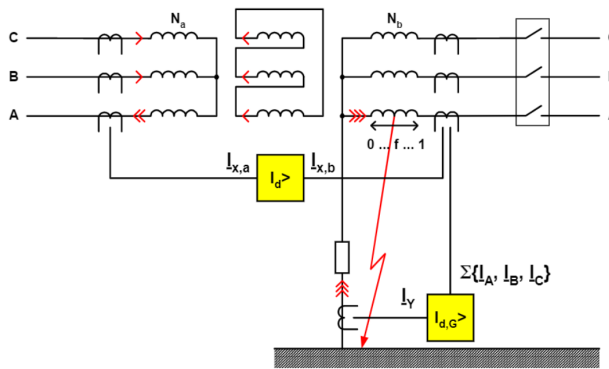

Fig. 1. REF and differential protection scheme

In some studies, high impedance REF protection scheme is presented as a recommended solution to improve performance of the relay [2]. In this scheme, relay turns into a voltage relay by adding a resistor to its coil circuit and voltage is measured instead of current for relay operation. In high impedance scheme all the CTs must have the identical specifications such as conversion ratio and saturation curve. They supply fault current for relay and stabilizing resistor which is connected in series with the relay coil. To achieve a high impedance scheme with high-speed operation time, measured voltage on relay during in-zone faults must be much higher than its setting value. [3]. For this purpose, knee point voltage of the current transformers must be twice or at least equal to stability voltage of the relay. Increasing knee point voltage to stability voltage ratio in high impedance scheme improves trip time and relay performance [4]. This scheme solves the problems caused by CTs saturation. But relay sensitiveness to internal faults will be reduced accordingly.

In this article, different fault types such as symmetric/asymmetric, single/multiple phases, low/high current are simulated. Then, causes of REF protection maloperation and commercial relays settings and curves are studied. Optimal setting for the relay is extracted and its effectiveness in different fault types validated by simulating real data with PSCAD and MATLAB software.

2. REF protection necessity for transformers

Let's assume that a phase to ground short circuit occurs at point f in Fig. 1. At the star point of the transformer, the value of f is equal to zero and at the end of the coil f is equal to one. The maximum fault current (I_{Gmax}) happens when f is equal to 1. In the other words, the highest fault current occurs when the fault happens at the end of the coil. In this case fault current has a linear relationship with the location of the fault (parameter f) and $2/3$ of the fault current feeds from the primary winding and the rest $1/3$ feeds from the tertiary winding. Differential currents (I_d) and Restricted Earth Fault (I_{dG}) current are calculated as follow:

$$I_{dG} = |I_Y| = f \times I_{Gmax} \quad (1)$$

$$I_d = |I_{A.a}| = \frac{2}{3} \times \frac{f \times N_b}{N_a} \times f \times I_{Gmax} \quad (2)$$

if the conversion ratio is 1, then:

$$I_d = \frac{2}{3} f^2 I_{Gmax} \quad (3)$$

As shown in Fig. 2, in case with Dyn vector group of transformers, differential and restricted earth fault current calculated as follow:

$$\begin{cases} I_d = \frac{1}{\sqrt{3}} \times f^2 \times I_{Gmax} \\ I_{dG} = f \times I_{Gmax} \end{cases} \quad (4)$$

According to above, in single phase to ground faults I_{dG} is greater than I_d . Therefore, differential protection will not operate for the faults which are close to the star point of the coil ($f \rightarrow 0$) due to negligible current I_d . In the other words, differential protection is less sensitive than REF protection to the phase to ground faults [5].

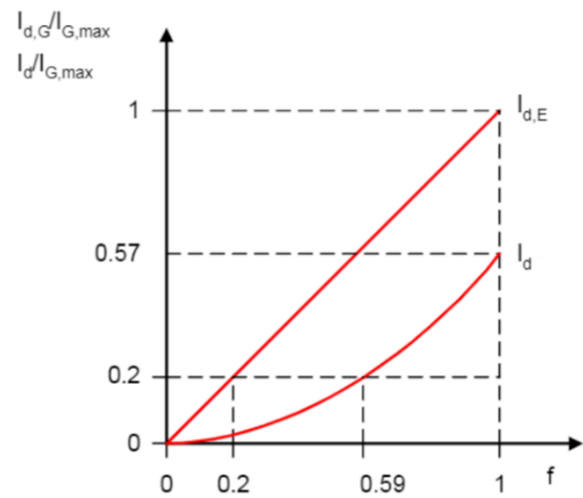

Fig. 2. DIFF and REF fault current for Dyn transformer

3. CTs Core saturation

The CTs core saturation has significant impact on REF protection and affects its sensitivity and speed. consequently, transient and steady state response of CTs must be considered during fault condition. The IEC 61869-2 defines the steady-state response of CTs and defines accuracy classes for different protection applications [6].

In the transient response of CTs, the magnetic flux density of the core is very important. This value is proportional to the area under the fault current curve [3]. CT primary side fault current has DC component in addition to AC component. The magnetic flux density (B) is proportional to the area under the magnetic flux curve Φ and naturally proportional to the current. The DC component of the fault current is much stronger than its AC component, causing transient magnetization in the CT core. According to the IEC60044-6, CT transmittance coefficient depends on the material of the core and its dimensions and size. So, with increasement of dimensions and size of CT, its transient coefficient will decrease and lead to decrees in DC magnetic flux. In phase-to-earth faults, there is a possibility of asymmetric saturation, but in three-phase and two-phase faults, the saturation is symmetrical and without DC offset [6].

When the fault cleared by Circuit breaker trip, due to its current and DC offset, magnetic flux density B is at its maximum value (B_{max}). Demagnetization in the CT secondary occurs simultaneously with the damping of the transient magnetic current and naturally the magnetic flux density is damped, but it does not decrease to zero and remains as residual flux (B_R) in the CT. Therefore, it should be noted that after the fault clearance, the CT may be affected by the magnetization caused by the DC component. This is shown in Fig. 3 [3].

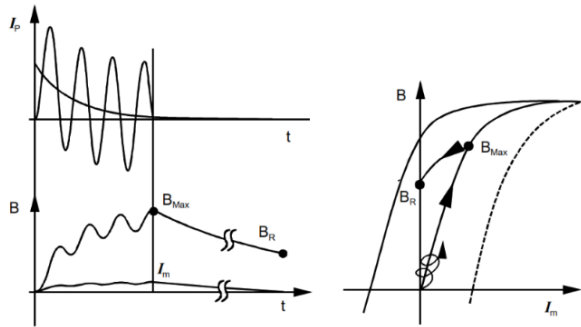

Fig. 3. The remanence flux in the CT core

The other important point is the effect of circuit breaker reclosing on CT residual flux. When reclosing is done before flux damping, more flux will flow in the CT and the core flux will exceed the permissible limit. This is explained in Fig. 4 [3].

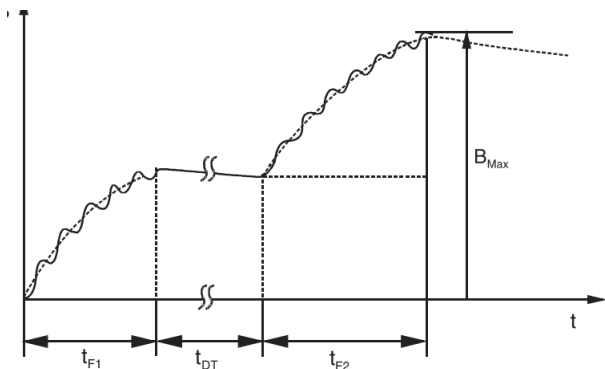

Fig. 4. Effect of reclosing on CT flux remanence

4. REF settings and operation curve

In the IEEE.C37.91 the restricted earth fault protection settings and operation curve are fully described. Also, in [4], [3] and [2], setting calculation for sample network is presented.

5. CT saturation effect on REF relay

In this section, the effect of CT saturation on relay operation in faults inside and outside the protection zone and especially the waveform of REF relay current is discussed. In Fig. 5, the neutral point current is I_1 , the vector sum of the phase currents ($3I_0$) is equal to I_2 , the bias current SI and the differential current are considered as DI . The waveforms of I_1 , I_2 , SI and DI currents in the condition of in-zone and out-of-zone faults are shown on the left and right side respectively [3].

During an internal fault, both differential and bias currents increase equally. When the CT saturation is happened, both differential and bias currents are still calculated as before. In this condition, the working point is above the relay current operation curve, and IOP/IRES operation point moves up and down on a line with an angle of 45 degrees and leads to relay operation and tripping (see Fig. 6). Consequently, CT saturation in internal faults does not affect the operation performance of relay and REF protection trips correctly [3].

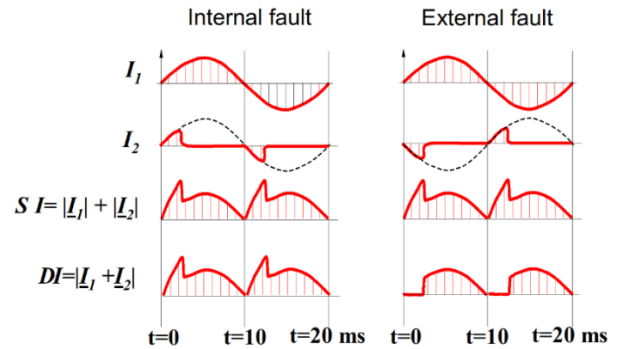

Fig. 5. In/out zone fault current during CT saturation

According to Fig. 6, when an external fault occurs, the IOP differential current remains zero in the first few samples until the CT saturation occurs, during this period, the IRES bias current increases. As long as the operating current of IOP is zero, the geometric location of the working point on the horizontal axis moves to the right, and with the onset of saturation, it jumps towards the error curve with a negative angle of 45 degrees, and from the error curve (curve with a slope of 45 degrees) to Zero moves. Considering that the fault is outside the zone, the REF protection should not work, but the value of DI with CT saturation is not zero and leads to the false operation of the REF protection [3].

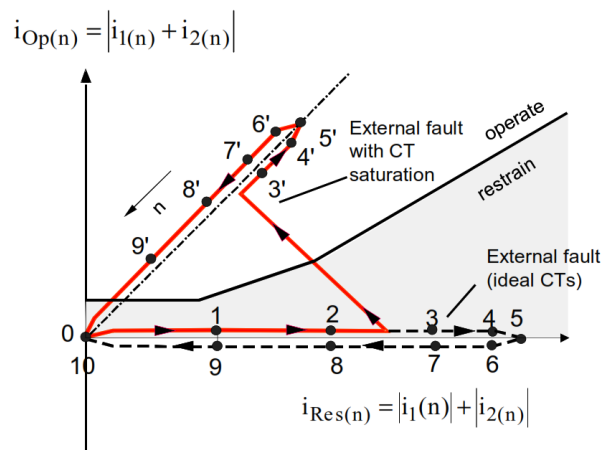

Fig. 6. Movement of operating point in REF curve with/without CT saturation

6. REF operation during fault conditions

Most of the relay manufacturer use same scheme for REF protection. The main idea is to use comparison of IOP or IREF operating current versus IRES bias current. However, to improve the relay's performance for different out zone fault conditions, manufacturers have made

changes in the calculation criteria of operation current and protection algorithm. In Table I. the formulas which used in the performance algorithm of the relays of prominent manufacturers are presented.

Table I. Calculation formulas for different REF relay manufacturers

Vendor	I_{REF}	$I_{RESTRAIN}$
SIEMENS-7UT63	$4 \cdot (I_Y - I_N - I_Y + I_N)$	$ I_Y $
ABB-RE-620	$\frac{ I_A + I_B + I_C }{3}$	$(I_N - I_Y) \times \cos \rho$
AREVA-PQ721	$ I_N $	$ I_N + I_Y $
GE 345	$(\max\{ I_{R0} , I_{R1} \}) \cdot$	$ I_N + I_Y $
Micom IP Max	$\frac{1}{2} (\max\{ I_A , I_B , I_C \} + I_Y)$	$ \sum\{I_A, I_B, I_C\} + I_Y $
Micom SUM (IP)	$ I_N $	$ I_N + I_Y $

To study transient behaviours of in zone/out zone faults considering CT saturation PSCAD software is used for simulation and MATLAB software has also been used to implement the algorithm for calculating currents and REF performance in two REF designs of low impedance SUM (IP) and IP-MAX of MICOM-P632 relay [2]. The sample network is a distribution substation with H design, which has two 63/20KV 15MVA power transformers with vector group Ynd11 and impedance percentage of 13.6%. REF protection is used to protects the low voltage windings, zigzag-transformer and Incoming feeder in 20KV panels. For this case study network, first we assume normal operating conditions then we study the operation of REF protection in different CTs saturation condition and fault types such as single-phase to ground, two-phase to ground and three-phase faults in no-load and full load.

a. Normal condition

In normal conditions and without fault, three phases current (a, b and c) are symmetrical. Id and IR values and related operating curves for MICOM-P632 relay with $I_{diff} \geq 0.1$ in both SUM (IP) and IP-MAX modes are shown in Fig. 7.

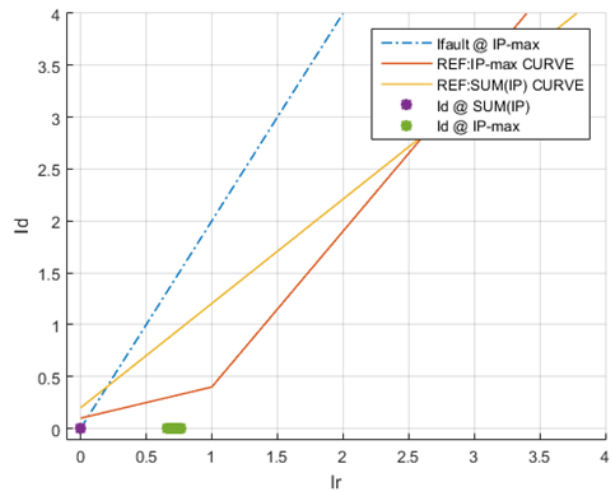

Fig. 7. SUM (IP) and IP-MAX mode's curves

The blue dashed line is the single-phase fault path in an ideal state inside the protection zone with IP-max scheme. The yellow line - single-slope - is the operation region boundary of the SUM (IP) mode which has a constant slope of 1.005. The red curve is the operation area boundary of IP-Max mode with settings, $m1=0.3$, $m2=1.5$, $I_{r-m2}=1$ (bi-slope performance curve). Purple and green points are the working point of SUM (IP) and IP-Max modes, respectively. In no-load condition and SUM (IP) mode, the working point is on the coordinate (0.0) and in IP-Max, the working point is around 0.7 on the horizontal axis (IR).

b. In-zone faults condition

For in zone faults REF relay has normally correct operation, so, the summary of the obtained results is mentioned in this section and additional details are mentioned in the appendix.

In the case of single-phase to ground fault and transformer loading condition, according to Fig. 8, Id changes with respect to IR in the SUM (IP) mode around the relay operation curve with a slope of 1.005. But in the IP-Max mode Id, due to the presence of grounding transformer resistance, the difference in the I_y and I_n current is high and there is more accuracy in fault detection by the relay. So, in both mode we have acceptable performance, but the reliability of IP-max is higher.

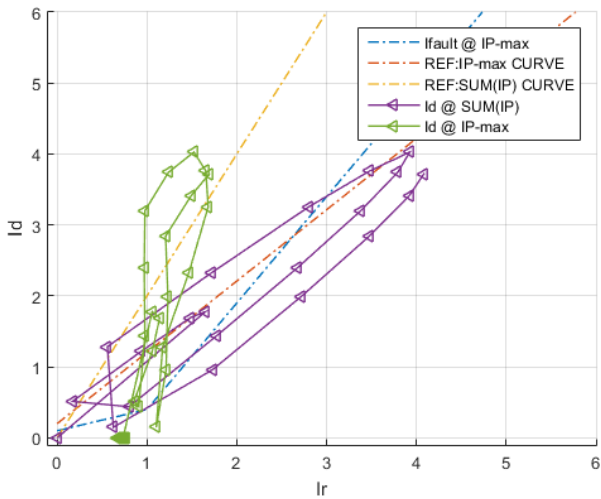

Fig. 8. REF curves for in-zone single-phase fault

In the two-phase to ground type faults inside the protection zone and with full load situation of power transformer, the I_d changes with respect to the I_r in the Sum (IP) mode around the relay operation curve at slope of 1.005. Whereas in the IP-Max mode the I_d movement path changes in the area between the operation curve and fault line. Nevertheless, both IP-Max and Sum (IP) in two-phase-to-ground faults will issue the trip command but IP-max mode has higher reliability.

In three-phase to ground fault inside the protection zone, there is no current passes through the neutral point due to the symmetry between the phases. So, in both SUM(IP) and IP-max modes REF protection will not be able to detect faults.

c. Out-zone faults condition

Many cases of REF relay maloperation is reported in out zone faults. To study this, REF relay operation for out zone faults with different conditions of CTs saturation and load condition of transformer is simulated. Despite of measures like steepening the operation curve of REF relay to prevent maloperation, outgoing feeders reclosing could increase the CTs core residual flux and lead to heavy saturation. Therefore, due to reclosing of out zone faults there is a possibility of maloperation in low impedance REF protection [4].

As shown in Fig. 9, both SUM (IP) and IP-Max modes in out zone single-phase to ground fault with any load condition the working point is near to the horizontal axis. But if we add CT saturation to this condition operation point will change its direction from the horizontal axis to the fault curve and cause maloperation (similar to what was described for Fig. 6 in section 2-3). Therefore, in the case of a single-phase fault to the ground outside the protection zone without CT saturation, both modes operate correctly, but in the case of high CT saturation in both Sum (IP) and IP-Max modes, there is a possibility of maloperation.

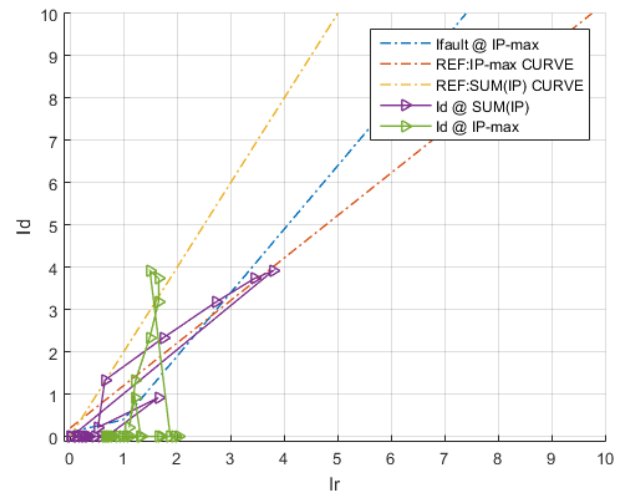

Fig. 9. REF operation curve for an out zone single phase fault with CTs saturation condition

In two-phase faults outside the protection zone, as shown in Fig. 10, in both no-load and full load condition of transformer Sum (IP) modes working point I_d is located near to (0.0) point and in the IP-Max mode working point moves near to the horizontal axis. Therefore, in both modes the working point is at the bottom of the relay operation curve, and maloperation does not occur. In the case of CTs saturation, no-load and full loaded condition the working point SUM(IP) mode moves below the operation curve parallelly and will not lead to relay maloperation. In the IP-max mode with CTs saturation working point changes its movement direction from horizontal axis towards the fault curve and will lead to wrong operation of the relay.

In Sum (IP) mode for two-phase-to-earth fault outside the protection zone in both no-load and full load condition I_d is changing between 0 and 1 near the horizontal axis and in IP-Max mode working point moves near the horizontal axis between 0 and 4. Therefore, in both modes operating point is below the relay operation curve and there is no maloperation.

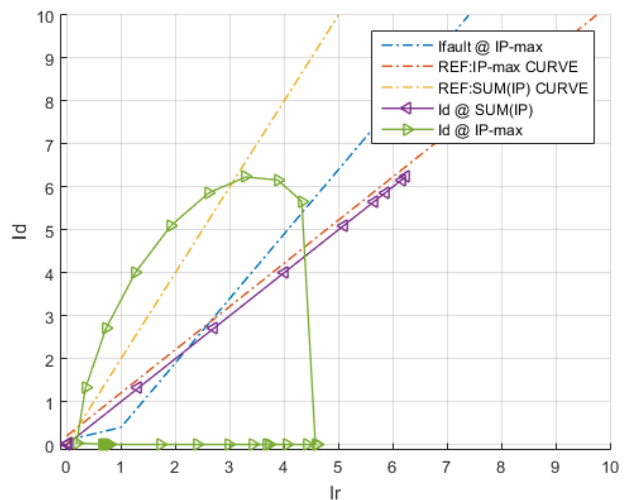

Fig. 10. REF curve for out-zone two/three phase faults with CTs saturation condition

As shown in Fig. 10, in two/three phase to ground faults with CT saturation condition working point of

SUM(IP) mode moves near below operation curve of the relay and probability of maloperation is low. In the IP-max mode with CT saturation, the direction of I_d changes its path from horizontal axis to the fault curve and leads to maloperation.

7. Summary of studies

Table II. compares the performance of low impedance and high impedance modes in different symmetric and asymmetric out-of-zone faults.

Table II. Study results for REF relay

Fault location	CT Saturation	Fault Type	MICOM P6xx	
			IP-Max	SUM(IP)
In Zone	Without	Phase - Ground	✓	✓
		Phase - Phase	✓	✓
		2 phase – Ground	✓	✓
		3 Phase	✓	✓
Out Zone	Without	Phase - Ground	✓	✓
		Phase - Phase	✓	✓
		2 phase – Ground	✓	✓
		3 Phase	✓	✓
	With	Phase - Ground	×	×
		Phase - Phase	×	✓
		2 phase – Ground	×	✓
		3 Phase	×	✓

The symbol ✓ indicates correct operation and × indicates the possibility of maloperation. As mentioned in table II, Micom-P6xx low impedance REF protection relay is reliable for external faults in no-load/full load conditions and without CT saturation with proper settings for both modes. But, in presence of CT saturation in out-zone faults SUM(IP) mode operate with higher reliability than IP-max mode.

In the other words, for REF relay in SUM(IP) mode only single-phase to ground faults with CTs saturation situation will cause incorrect operation, whilst in IP-max mode maloperation may occurs for all out-zone fault types.

8. Conclusion

In this study operation of REF protection relays in different fault types and CTs saturation conditions in two usual relay operation setting curves which has single or double steps are checked. To simulate real condition operation of commercial relays, two common low impedance REF designs modes SUM (IP) and IP-MAX of MICOM-P632 relay are used. The result shows that using the IP-Max setting does not completely cover all the weaknesses of low-impedance REF protection algorithm while Sum (IP) mode has higher reliability and this setting in most faults has correct operation. Since the main cause of maloperation of REF relay is CTs saturation, it is recommended to use CTs with higher specifications, larger core dimensions and lower burdens in secondary circuits to improve performance of REF relay [3].

9. References

- [1] A.-P. A. Handbook, "BU Transmission Systems and Substations ABB Transmission and Distribution Management Ltd book no (6)," BA THS/BU Transmission Systems and Substations, PO Box 8131, Switzerland, 1990.
- [2] Bereich Schutz- und Schaltanlagenleittechnik (Protection and Control), Transformator-Differential Protection Device P631 / P632 / P633 / P634, ALSTOM Energietechnik GmbH.
- [3] G. Ziegler, Numerical Differential Protection: Principles and Applications, Wiley, 2012.
- [4] MiCOM 30 Series Restricted Earth Fault Protection Application Guide, ALSTOM, 2003.
- [5] A. G. Worldwide, NETWORK PROTECTION & AUTOMATION, ALSTOM GRID, 2011.
- [6] I. 61869-2:2012, Instrument transformers - Part 2: Additional requirements for current transformers, International Standard, 2012.
- [4] "IEEE Guide for Protecting Power Transformers," IEEE Std C37.91-2008 (Revision of IEEE Std C37.91-2000), pp. 1-139, 30 May 2008.

10. Appendix

Due to the limitation of this article, to receive the following appendix please send a request email to the addresses of the authors.

Appendix 1: Sample protection calculation with MicOM-P632 REF relay.

Appendix 2: The operation of SUM(IP) and IP-max modes and the comparison of these algorithms with complete forms of three-phase and neutral currents during symmetric and asymmetric external faults.